

CVA10 Board Stops Fitting Instructions

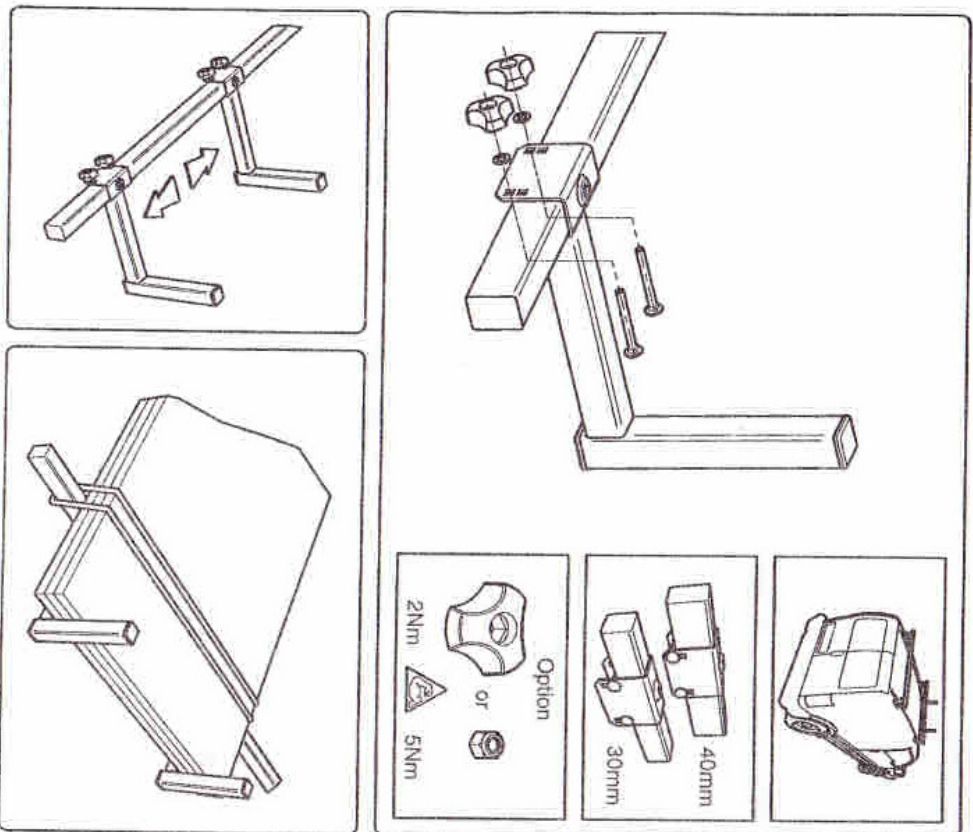

Retain these instructions for future reference, ensure that other users of the commercial bar system are familiar with their contents.

Your roof bar systems maximum recommended load must not be exceeded, and the vehicle manufacturer's directions as to maximum recommended load must be observed (This can be found in the vehicle's owners handbook).

Maximum load = The weight of the load carrier + the weight of the load.
It is very important to ensure that all loads are evenly distributed across the load bars and are safely secured using suitable fixing methods (e.g. strong webbing straps with buckles).

If small heavy loads are being carried, load to one side of the bar, not the middle.
Where specialised accessories are available, they should be used (e.g. Pipe Clamps, etc).

Before driving and at regular intervals during your journey, check that all securing screws, clamping devices and foot attachments are fully tightened in accordance with these instructions.

When using the bars, especially when carrying a load, the driving characteristics of your vehicle will change. Driving techniques should be altered to allow for this. Reduce speeds and allow longer braking distances.

When fitted, the roof bars will affect your fuel economy, therefore please remove when not in use.

Neither the roof bars nor load must project beyond the maximum profile of the vehicle.

Ensure these roof bars are maintained and kept in good working order.

Take care not to drive in low places such as garages or multi-storey car parks when carrying a high load.

Surf Boards, timber and large flat objects may produce damaging aerodynamic forces to the vehicle, out of all proportion to their dead weight. We therefore recommend travelling at much reduced speed when carrying these articles. Where two or more surfboards are carried (or similar items which may produce lifting forces) they should not be carried side by side, but should be stacked one upon the other. They should each be secured independently to the front and rear of the vehicle using straps or methods that are capable of withstanding the lifting forces.

Do not put the car through an automatic car wash with the load carrier mounted.
The distance between front and rear load bar should be at least 700mm (unless otherwise stated by the vehicle manufacturer).

There is some risk that the paint under the foot rubbers may not match any fading of the vehicle paintwork. To avoid this, we recommend the cleaning of the load bar feet and the vehicle roof prior to fitment. The load bars should be removed at regular intervals to repeat this process.

Mont Blanc Industri UK Ltd.
Eden Way, Pages Industrial Park, Leighton Buzzard, Bedfordshire. LU7 4TZ.
www.montblancuk.co.uk

The manufacturer operates a policy of continual development and reserves the right to alter specifications without prior notice. Therefore, due to the possibility of improved design, contents may vary from those shown.